

Angle Unit-Adjustable

Part #: MZQT46-ER16-AD-HS

Mimatic Part #(old): 05.1914.7840.402
Mimatic Part #(new): 125055

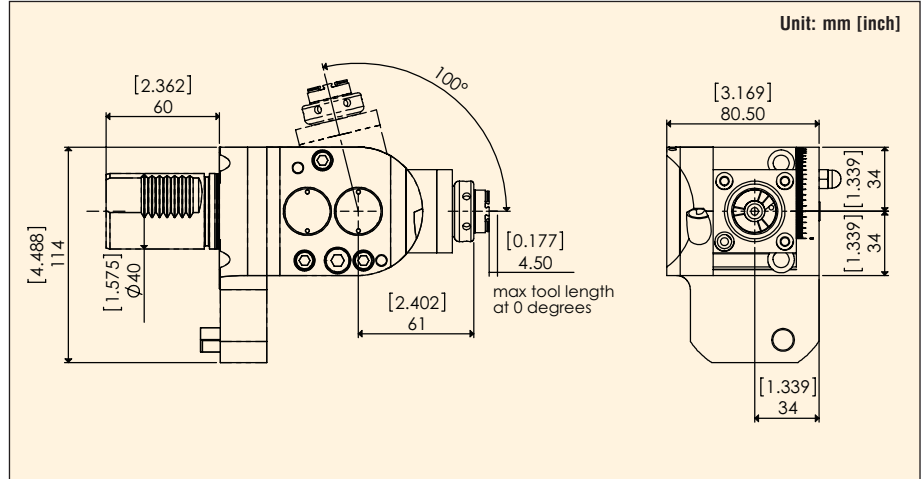

Collet Size	Clamping Range	Max. Torque	Input/Output RPM (Max.)	Gear Ratio	Input/Output Rotation	Coolant	Spindle Wrench	Nut Wrench
ER16	0.5-10mm	6 Nm	3750/15000	1:4	CW-CW	External	107557	112954

Please refer to pages 44 - 47 for ER Series Collets and ER Tap Collets details.

Y-Unit Adjustable

Part #: MZQT46-ER25Y-AD

Mimatic Part #(old): 05.0511.7841.404
Mimatic Part #(new): 124120

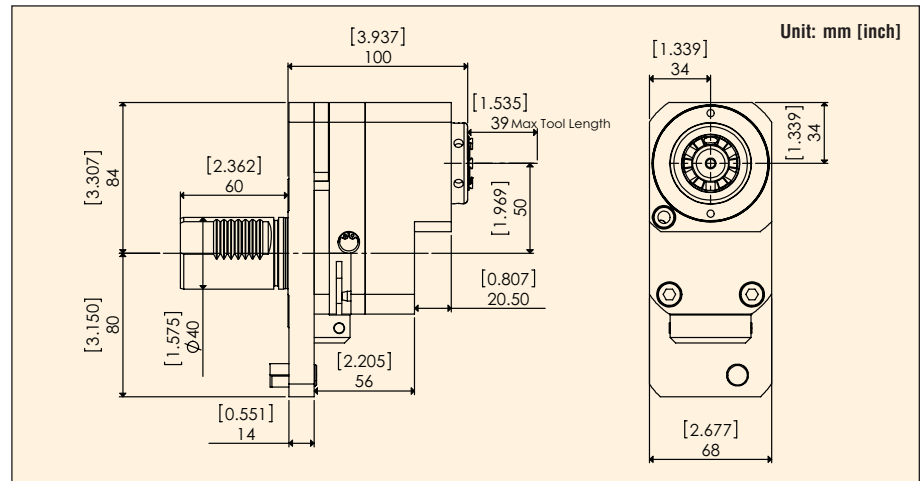
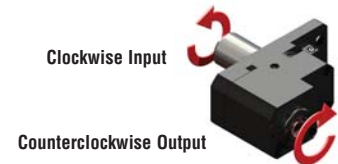

Collet Size	Clamping Range	Max. Torque	Input/Output RPM (Max.)	Gear Ratio	Input/Output Rotation	Coolant	Spindle Wrench	Nut Wrench
ER25	0.5-16mm	25 Nm	6500/6500	1:1	CW-CCW	External	107446	112913

Please refer to pages 44 - 47 for ER Series Collets and ER Tap Collets details.